

LD175 with new E1 LED Light Engine



High Power Square Recessed Low Glare Interior/Exterior Floor Washer

Data sheet - Page 1

The LD175 features the new E1 LED engine; brighter and more efficient than the previous generation LED. LD175 is designed for lighting installations where a very high output is required over what the LD59 is capable of producing. LD175 builds upon the LD59, with its remarkable uniform floor washing capabilities, together with its broad diffused beam shape and 410 lumen output, it is ideal for larger external projects.

LD175 features a high quality machined anodised body and is IP67 rated making it suitable for both internal and external lighting installations. This shallow recess depth wall light has the LED and diffuser assembly recessed deep within the fitting ensuring low glare.

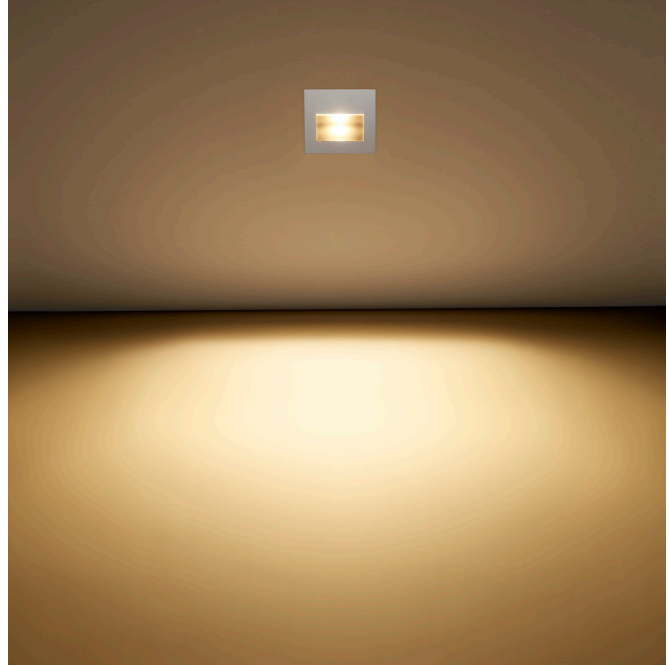

Key Features

- New E1 engine, featuring the CREE XHP35 LED with 2-step binning
- Impressive uniform floor washing capabilities
- Very broad diffused beam shape
- High output, ideal for lighting wider pathways
- Reduced glare with the LED and diffuser assembly recessed deep within the fitting
- IP67 as standard
- Polished 316 stainless steel bezel as standard, with other finishes available
- No visible fixing
- Maintenance-free operation
- Built-in reverse polarity protection
- Optional first fix concrete-in back box
- LD175 is also available with RGBW and Tunable White LED engines
- Available with Switch, 0-10V, DMX, Dali or Mains dimmable drivers

Specification

Applications



LED type	1x E1 LED Engine with 2-step binning (LED data below)			
Colour temperature	2700K** / 3000K / 4000K		5000K	
Drive Current (mA)	350	500	350	500
LED power (W)	5W (4.4W)*	7W (6.3W)*	5W (4.4W)*	7W (6.3W)*
CRI (typical)	85	85	80	80
Forward voltage (V) ₁₀₀	14V	14V	14V	14V
Delivered lumens (L ₁₀₀)	323	410	351	441
Lumens per circuit watt	66	59	70	63

LED lifetime (to 70% lumen maintenance) 50,000hrs at a max ambient temperature of 35°C (if specifying fitting in ambient temperatures of up to 45°C run at 350mA max, LD175-350)

Materials Machined anodised aluminium body with a 316 stainless steel bezel (other options available)

Glass 2mm thick borofloat glass

Wiring Comes pre-wired with 200mm lead. Single colour equipped with 2 core cable, TW engine with 4 core cable & RGBW with 8 core cable. Can be specified with up to 10m at extra cost.

IP rating IP67

*indicates the nominal power for the LED run at that particular current and includes losses associated with using an 85% efficient driver

**2700K lumen output is 8% lower than the 3000K figure listed

/SC - Spring clips



/CB - Concrete box

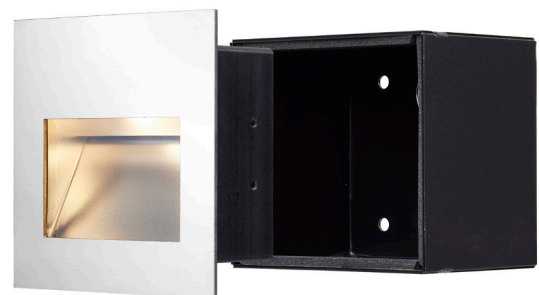

LD175 with new E1 LED Light Engine



High Power Square Recessed Low Glare Interior/Exterior Floor Washer

Data sheet - Page 2

Dimensions and Fixing Options

/SC - Spring clips

Spring clips are supplied as standard when the concrete-in box is not specified. This fixing option is suitable for the majority of installations.

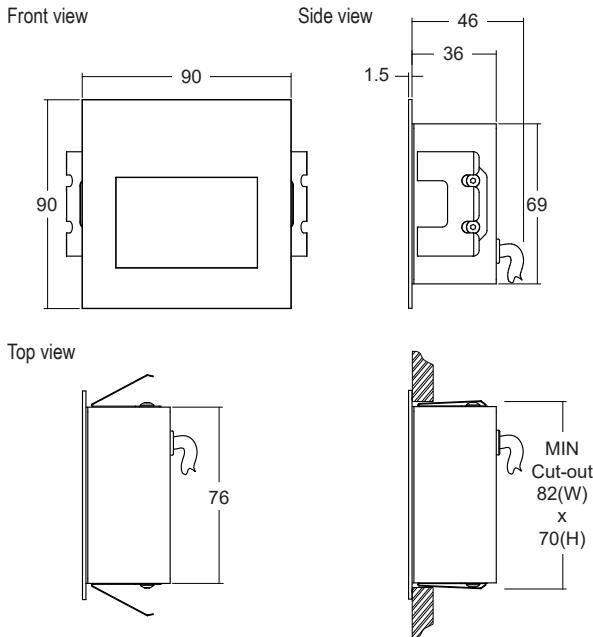

/CB - Concrete box

First fix concrete-in box offers the ability to create the correct void in a concrete wall necessary to fit the LD59. There is space behind the product to make connections (internal use only). Please note spring clips are not supplied when the concrete-in box is specified. The fitting is held in place with a silicone gasket provided within the box.

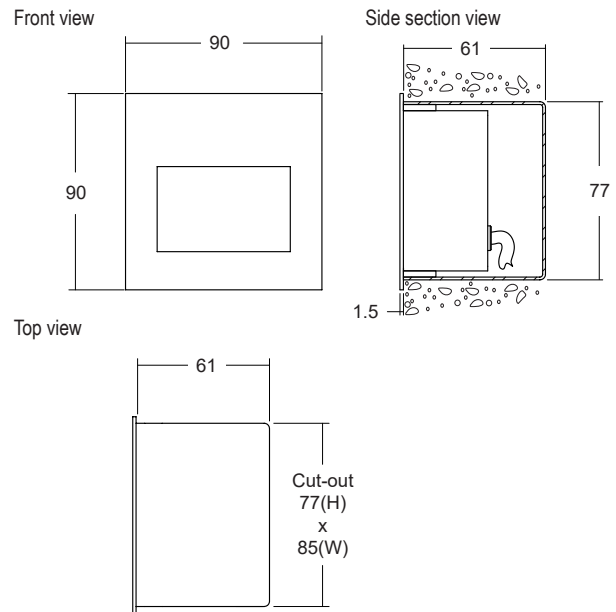

LD175 with new E1 LED Light Engine

High Power Square Recessed Low Glare Interior/Exterior Floor Washer

Data sheet - Page 3



Product Features

BEZEL

Stainless steel, paint finish white (RAL 9016) / black / RAL. Other paint finishes available, please talk to sales.



REFLECTOR

High efficiency reflectors designed to project light down and across the lit surface.

DIFFUSER

Softening the light output and broadening the beam.

BODY

Machined and anodised body. Grade of aluminium chosen for its thermal characteristics and resistance to corrosion.

LED

- E1 LED engine.
- TW Tunable White LED engine.
- RGBW LED engine with colour mix lens.
- CLR Colour LED engine.

FIXING OPTIONS

Choose between spring clips or the concrete box fixings options.



LD175 with new E1 LED Light Engine

High Power Square Recessed Low Glare Interior/Exterior Floor Washer









Data sheet - Page 4



LED Options and Technology

New LED Options

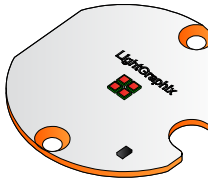
LD175 is now available with a choice of light engines which feature a new all copper board for increased thermal transfer. The new E1 light engine for white light applications uses the new Cree XHP35 LED and features on board polarity protection. This smaller LED chip has enabled a wider range of beam angles to be offered, coupled with increased efficiencies. This engine is also available with two extra LEDs on a second channel, for night lighting and marine navigation applications. The new tunable white engine offers a choice of dynamic colour options.

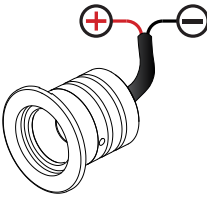
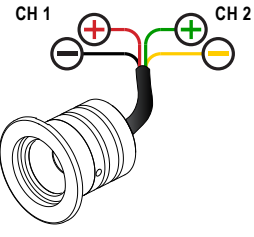
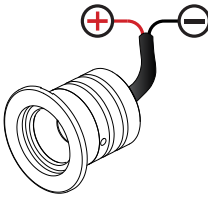
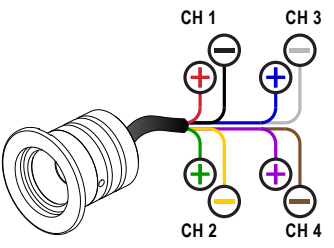
	E1 Light Engine (White light applications) 	Tunable White (TW) 	CLR - Colour 	RGBW 
LED Board				
LED type	Cree XHP35	Cree XQE's	Cree XQE's	Cree XQE's
Key features	<ul style="list-style-type: none"> - Available in 2700K, 3000K, 4000K and 5000K - Very small chip size - Tighter narrow beam - Wider range of beam angles - 2 step binning - Brighter more efficient LED - On board polarity protection - All copper LED board for increased thermal transfer 	<ul style="list-style-type: none"> - 4 XQE LEDs - 2 LEDs per colour - Excellent dynamic white mixing from a range of optics - All copper board - Same board is populated with Red, Blue, Green and Amber colour LEDs (CLR Light Engine) 	<ul style="list-style-type: none"> - 4 colour XQE LEDs mounted under a single optic - All copper LED board - Red, Blue, Green and Amber colour LED options - Single LED circuit 	<ul style="list-style-type: none"> - 4 XQE LEDs - White LED is 4000K - All copper LED board
Cables				

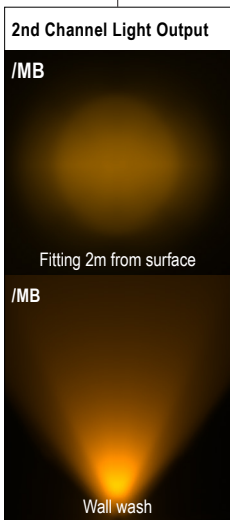

Industry Leading LED Thermal Management

High quality, embedded copper PCB, with direct contact cooling for the LEDs providing industry leading thermal management of the LED. Guaranteeing long life and minimal colour shift.



LD175 with new E1 LED Light Engine



High Power Square Recessed Low Glare Interior/Exterior Floor Washer

Data sheet - Page 5

Order Codes and Options

White LED Options - E1 Light Engine

Product code	LED colour	Finish	Fixing
LD175-E1 - 350 - 500	<input type="text"/>	<input type="text"/>	<input type="text"/>

Example: LD175-E1-500 / LW30 / Stainless steel / SC

Product codes with output options

5W LED at 350mA	LD175-E1-350
7W LED at 500mA	LD175-E1-500

LED colour options

LED colour options	Suffix
Extra Warm White (2700K)	/LW27
Warm White (3000K)	/LW30
White (4000K) - on request	/LW40
Cool White (5000K)	/LW50

*Other LED colour temperatures are available. Please speak to a member of our sales team.

Finish options

Polished stainless steel 316
 Polished and passivated stainless steel 316 (marine grade polish)
 Brushed and passivated stainless steel 316
 Paint finish white / black / RAL

Fixing Options

Spring clips	/SC
Concrete-in back box	/CB

Use with 350mA and 500mA constant current LED drivers

We have a wide range of dimmable LED drivers, 0-10V, DMX, DALI and Mains dimmable. Please see the downloads section on our website:
 To run 1-4 LD175-E1-350 in series use a TXDEL350D (0-10V dimmable)
 To run 1-4 LD175-E1-500 in series use a TXDEL500D (0-10V dimmable)

Colour LED Options - CLR Light Engine

Example: LD175-CLR-500 / LR / Stainless Steel / SC

LED colour options

LED colour options	Suffix
Red	/LR
Green	/LB
Blue	/LG
Amber	/LA

Driver requirements identical to E1 engine, beam angles identical to TW engine

Tunable White Options - TW Light Engine

Product code	LED colour	Finish	Fixing
LD175-TW - 350 - 500	<input type="text"/>	<input type="text"/>	<input type="text"/>

Example: LD175-TW-500 / LW27 + LW40 / Stainless steel / SC

Product codes with output options

5W LED at 350mA - 2 channels of 2 x 1.2W	LD175-TW-350
7W LED at 500mA - 2 channels of 2 x 1.7W	LD175-TW-500

LED colour options

LED colour options	Suffix
Tunable White 2700K & 4000K (standard option)	/LW27 + LW40
Tunable White 2700K & 5000K	/LW27 + LW50
Custom	/LW** + LW**

Fitting comprised of 2x LEDs in one colour temperature & 2x LEDs in another.
 Other white colour options available on request, please discuss with our sales team.

Finish and fixing options

Same as White LED options using the E1 Light Engine

Use with 350mA and 500mA constant current LED drivers

We have a wide range of dimmable LED drivers, 0-10V, DMX, DALI and Mains dimmable. Please see the downloads section on our website:
 To run 1-7 LD175-TW-350 in series use 2x TXDEL350D (0-10V dimmable)
 To run 1-7 LD175-TW-500 in series use 2x TXDEL500D (0-10V dimmable)

Colour Change RGBW Options - RGBW Light Engine

Product code	LED colour	Finish	Fixing
LD175-RGBW - 350 - 500	<input type="text"/>	<input type="text"/>	<input type="text"/>

Example: LD175-RGBW-500 / Stainless steel / SC

Product codes with output options

5W LED at 350mA (4x 1.2W LEDs)	LD175-RGBW-350
7W LED at 500mA (4x 1.7W LEDs)	LD175-RGBW-500

RGBW features a 4000K white LED

Finish and fixing options

Same as White LED options using the E1 Light Engine

Use with 350mA & 500mA constant current LED drivers

We have a range of dimmable LED drivers DMX and DALI compatible. Please see the downloads section on our website:
 To run 2-13 LD175-RGBW-350 in series use a TXDEL4A350DMX or TXDEL4A350DALI
 To run 2-13 LD175-RGBW-500 in series use a TXDEL4A500DMX or TXDEL4A500DALI